

Latest trend in Networking: Software Defined Network (SDN)

J K Mandal

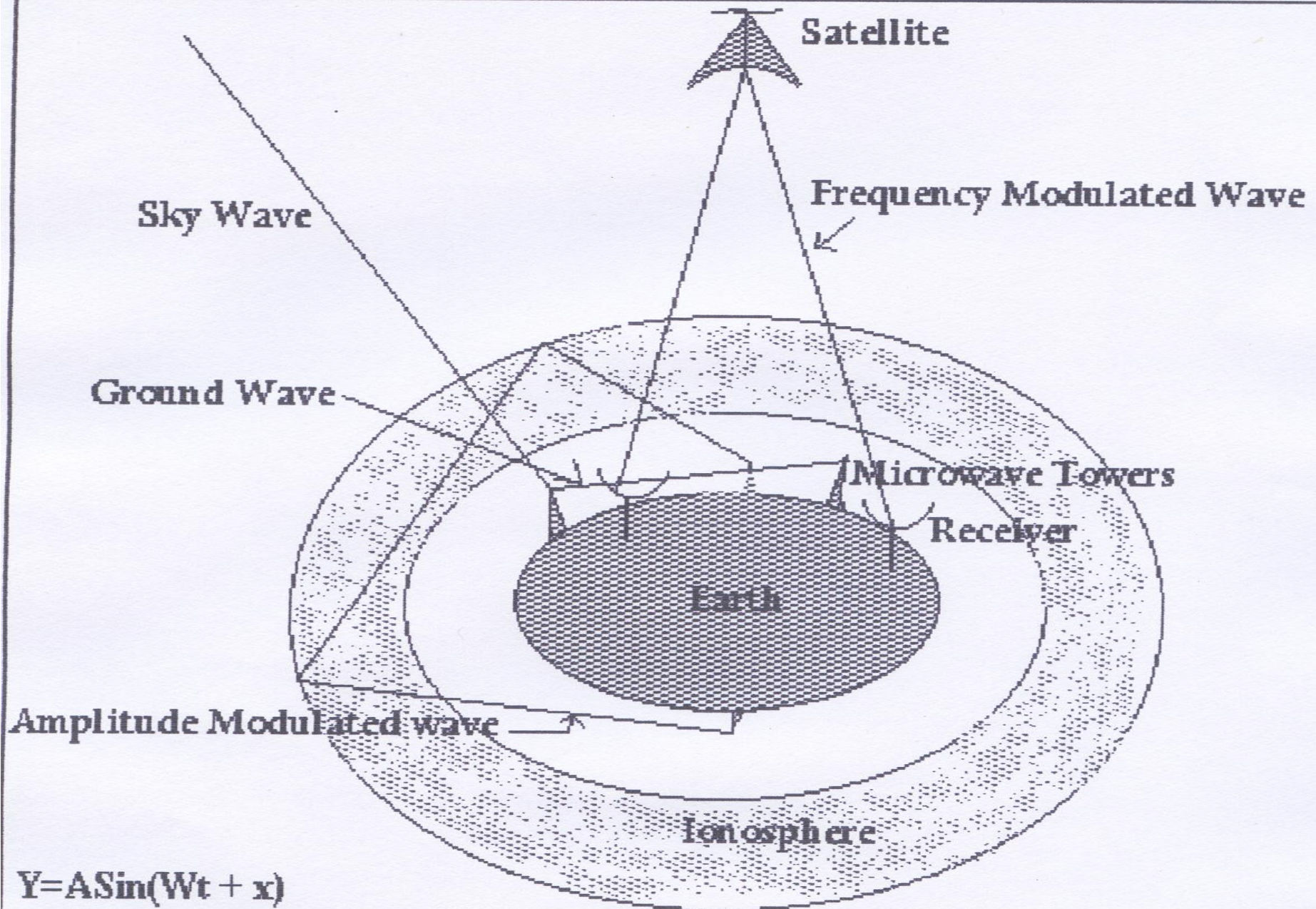

$Y = A \sin(Wt + x)$
 A = Amplitude x = Phase
 W = Frequency

Communication

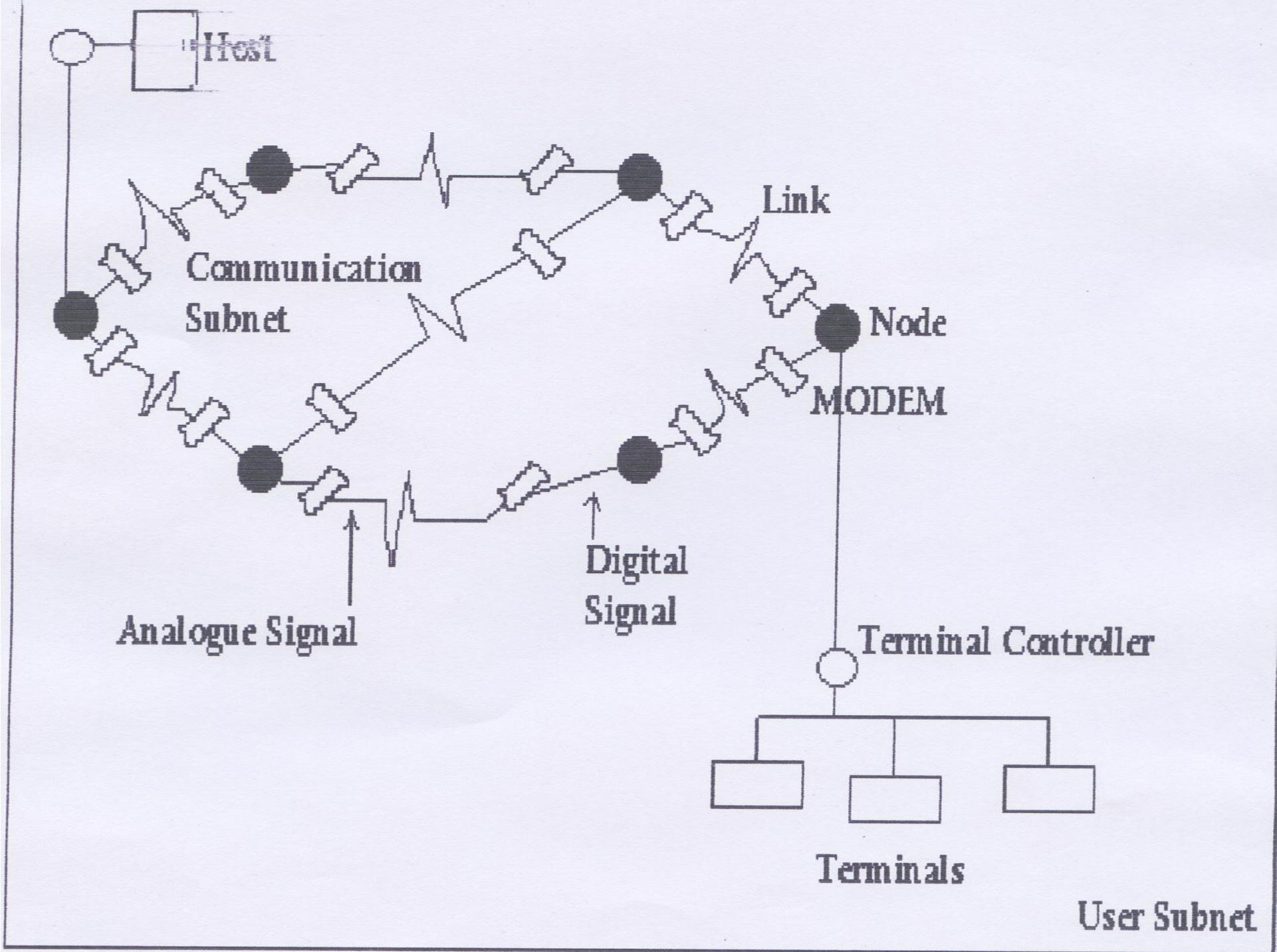

INTRODUCTION

-In the early 1980s when desktop computers began to proliferate in the business world, the intent of their designers was to create machines that would operate independently of each other. The computing idea was summed up with "One User, One Computer" which means that individuals were free to manage information on their own desktop.

Some of the common objectives of computer communication networks are:

- To provide sharing of (distant) resources such as information (database) or processors(CPUs). Resource sharing is perhaps the most common objectives providing networks, within the constraints of cost and reliability of transmission links.**
- To provide inter-process communication, such as among users (or processes) and processors. Network users, located geographically apart, may converse in an interactive session through the network.**
- To improve reliability of network through backup and redundancy. If one processor breaks down, another processor in the network can take its place.**
- To furnish centralized control for geographically distributed system.**
- To provide centralized management allocation of network resources**
- To provide compatibility of equipment and software.**
- To provide network users better performance at minimum cost .**

There are three types of functions in network nodes

Source-destination Function

Store-and-Forward Function

Networkwide Functions

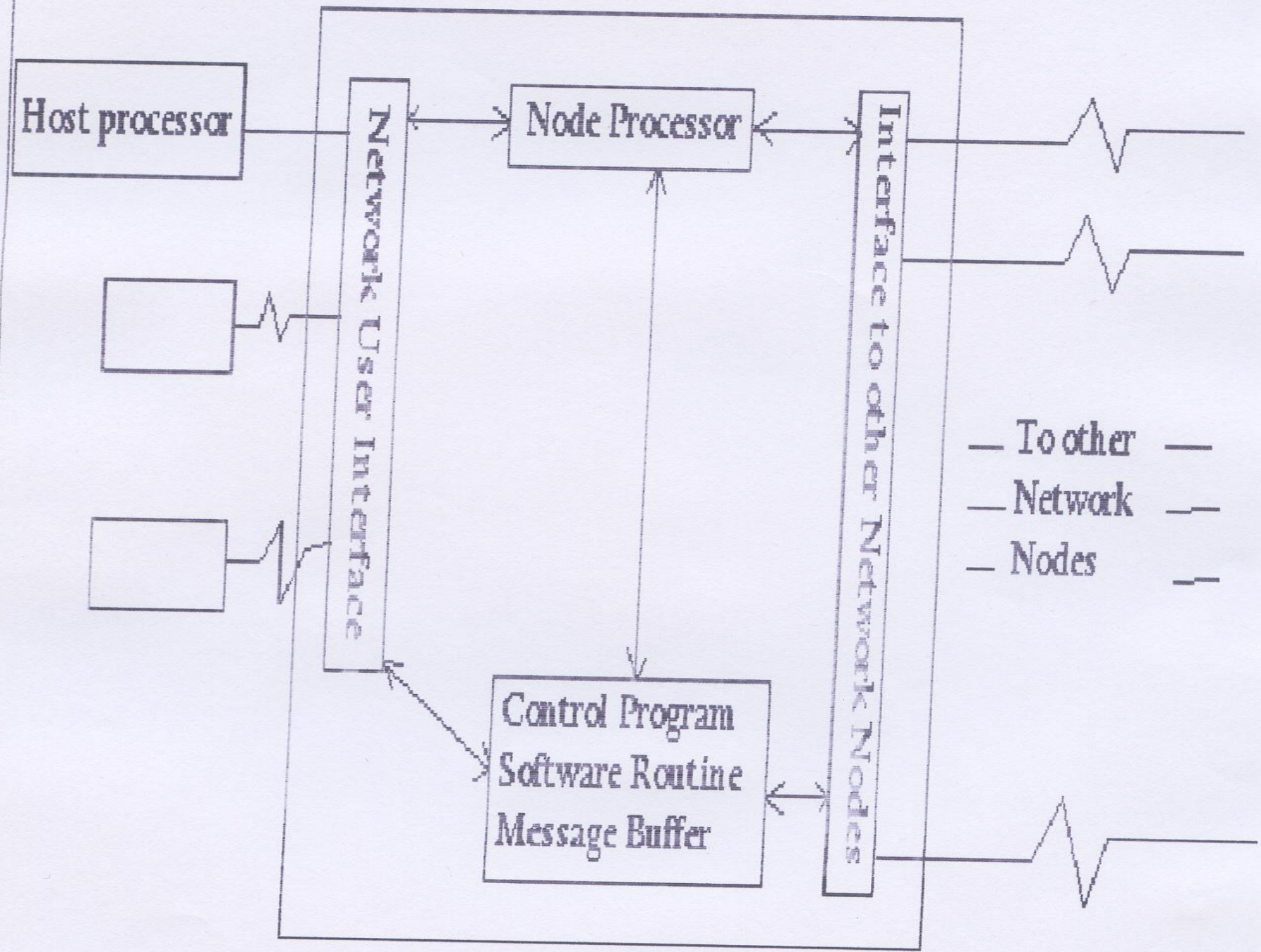

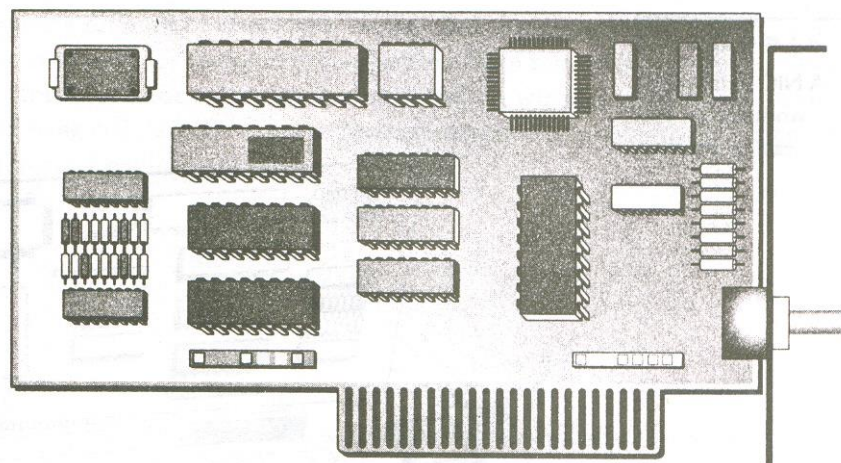

TOPOLOGY

- POINT-TO-POINT CHANNELS
 - Star
 - Loop
 - Tree
 - Intersecting Loop
 - Irregular
- BROADCAST CHANNELS
 - Bus
 - Satellite or Radio
 - Ring

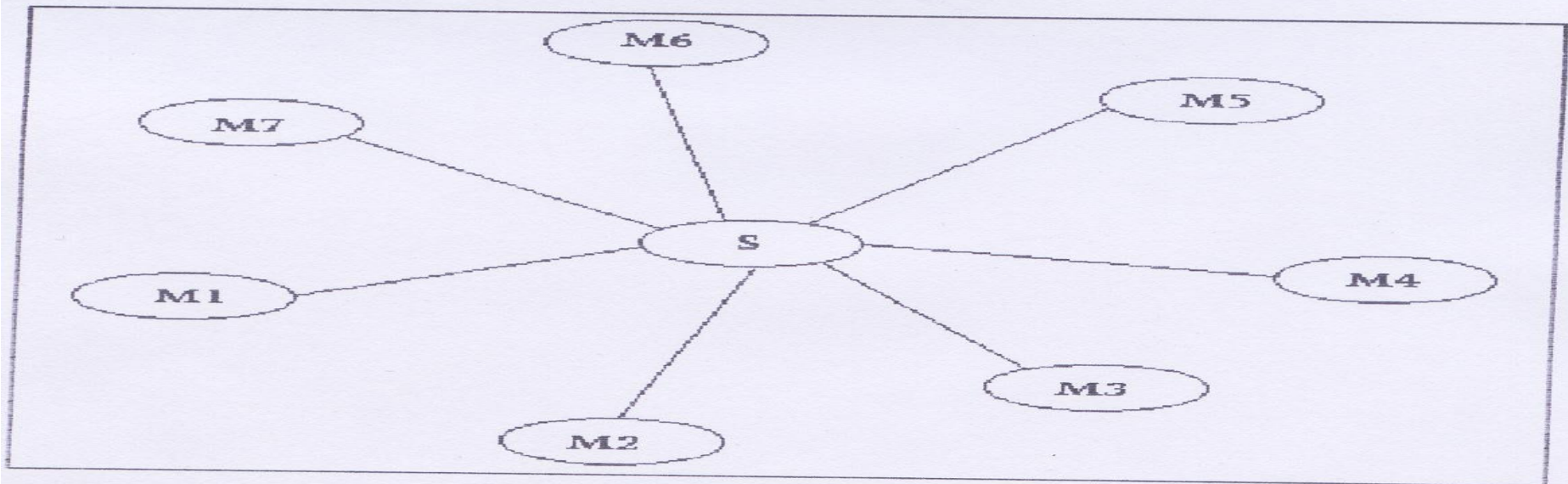
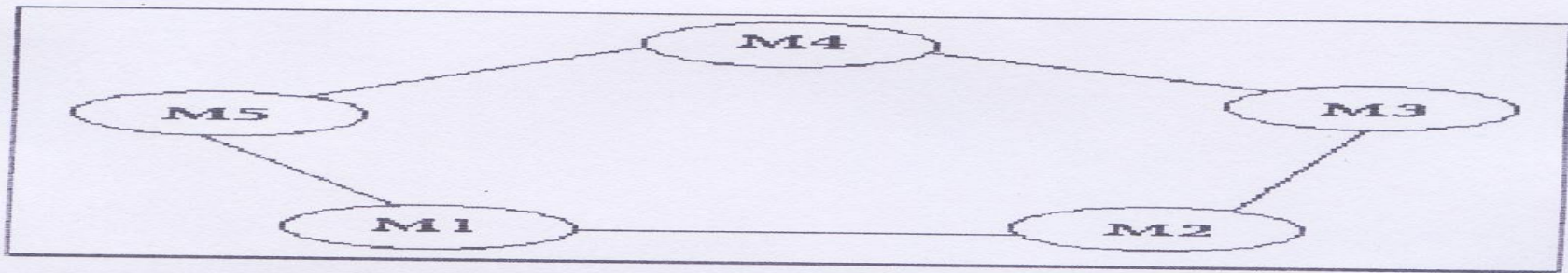
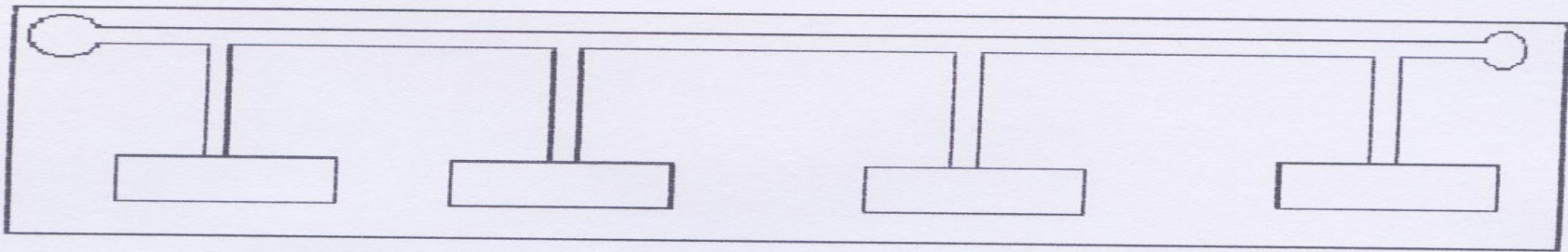

BUS TOPOLOGY OF LAN

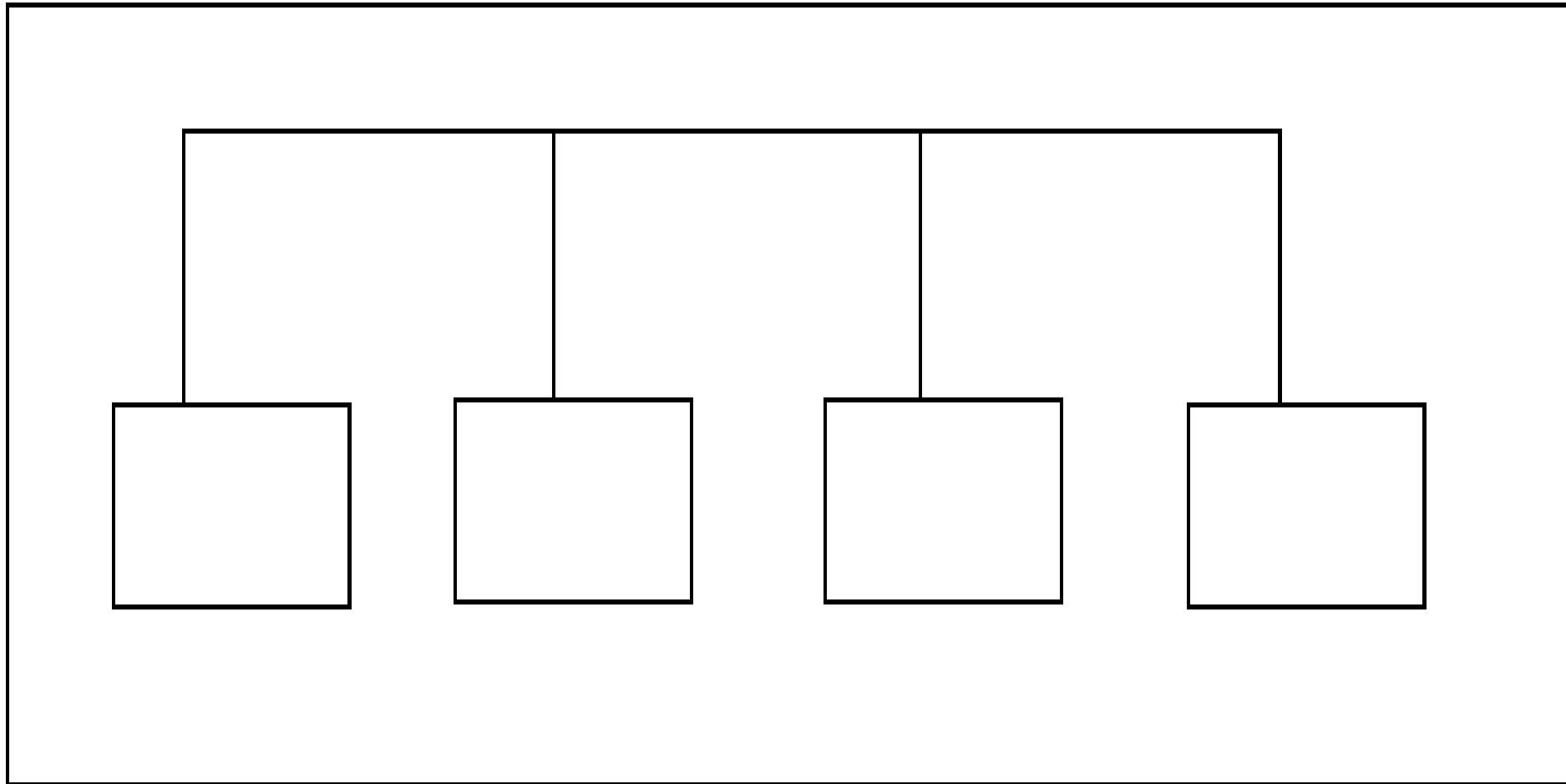

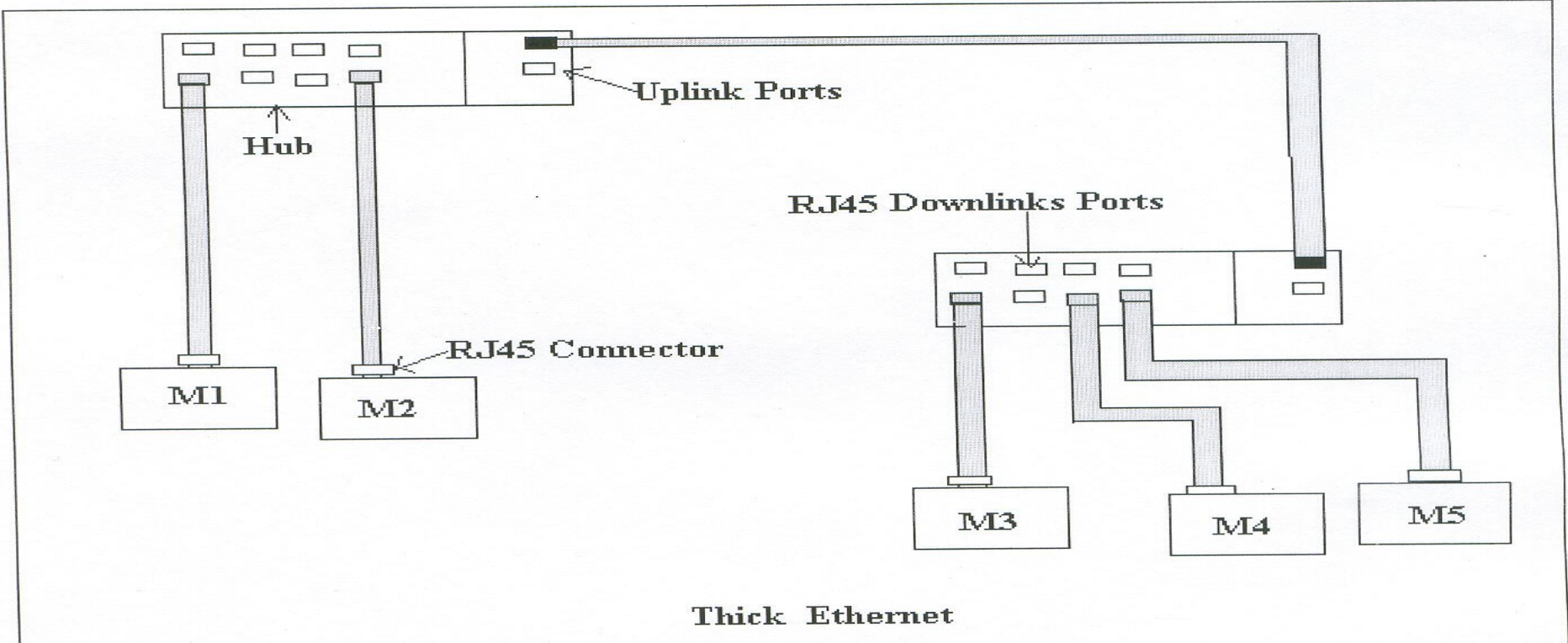
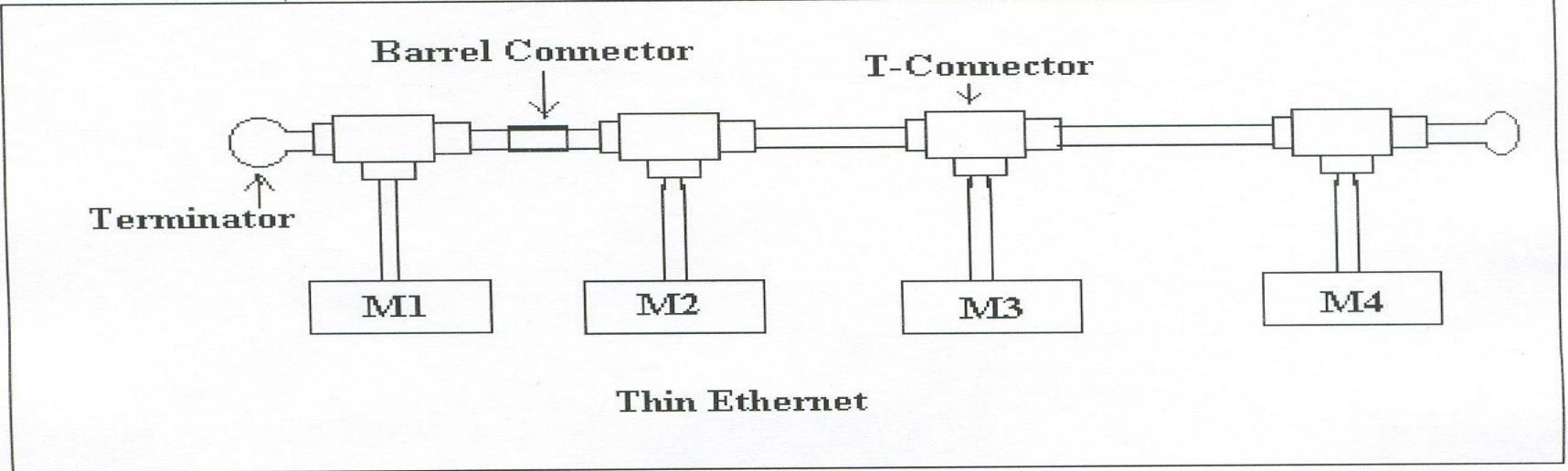

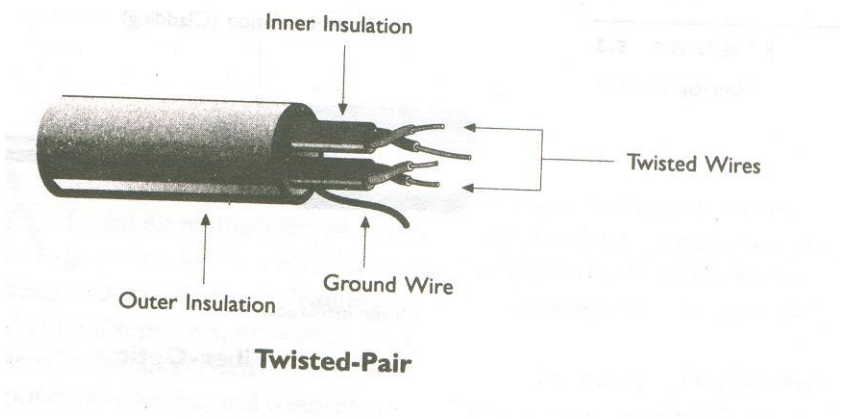
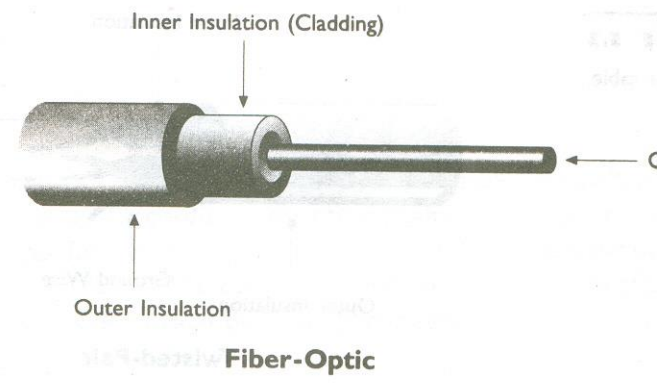
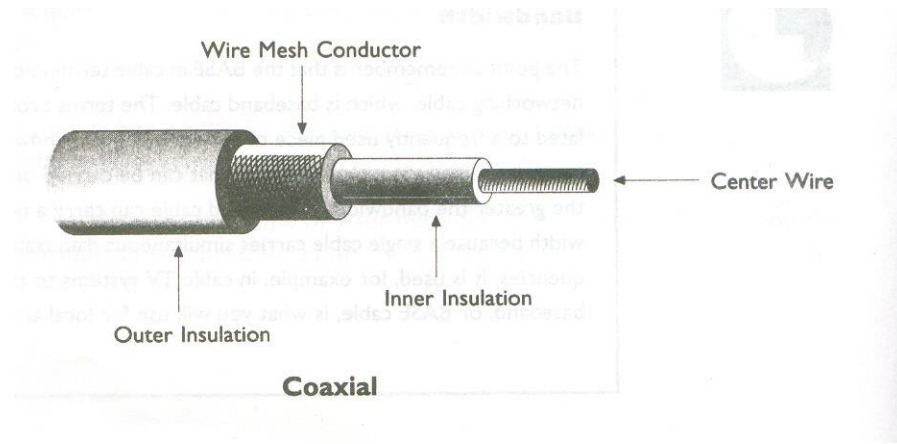

SWITCHING TECHNOLOGIES

- CIRCUIT SWITCHED NETWORK**
- MESSAGE SWITCH NETWORKS**
- PACKET SWITCHED NETWORKS**

HUB/SWITCH BASED LAN

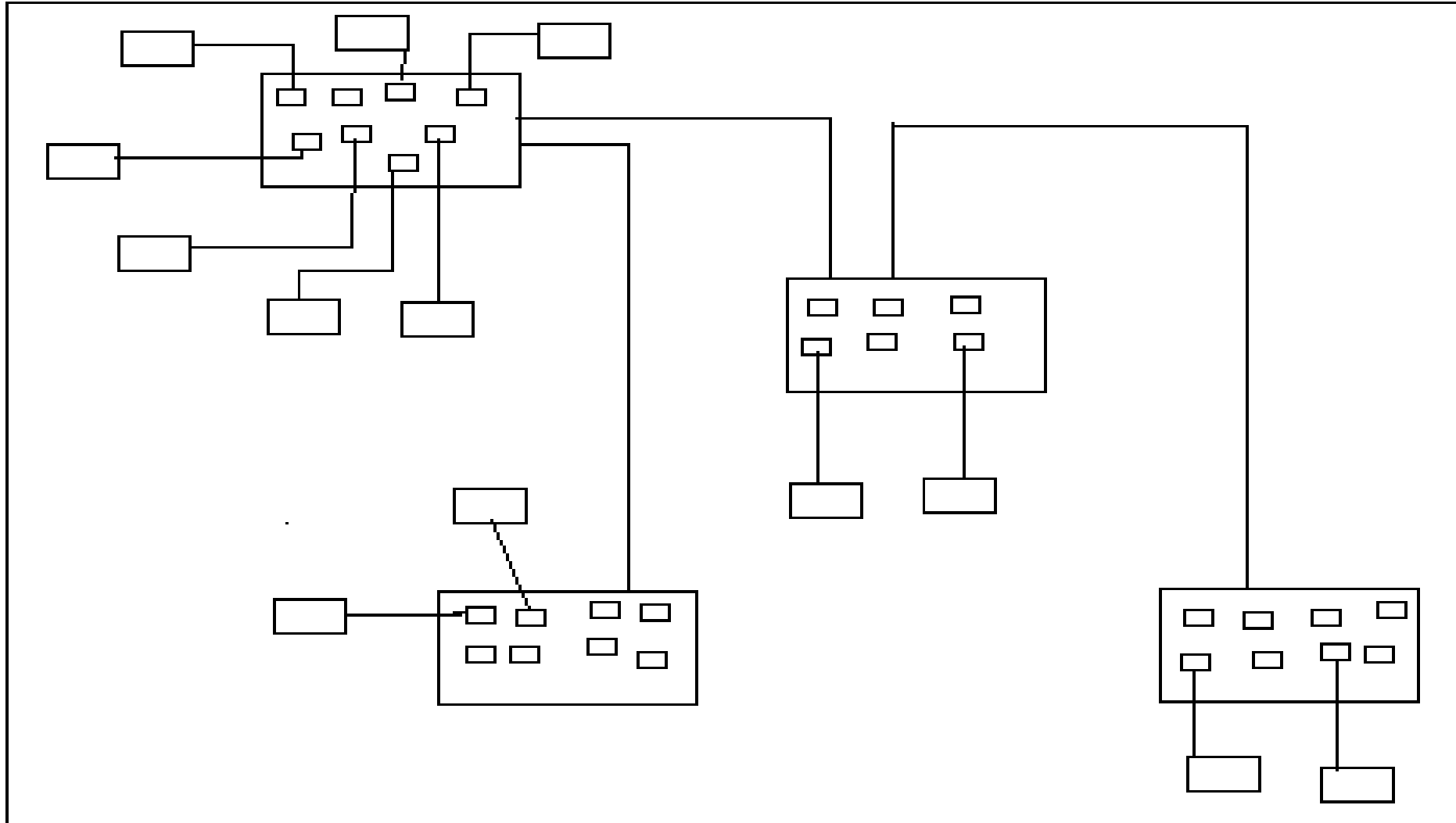

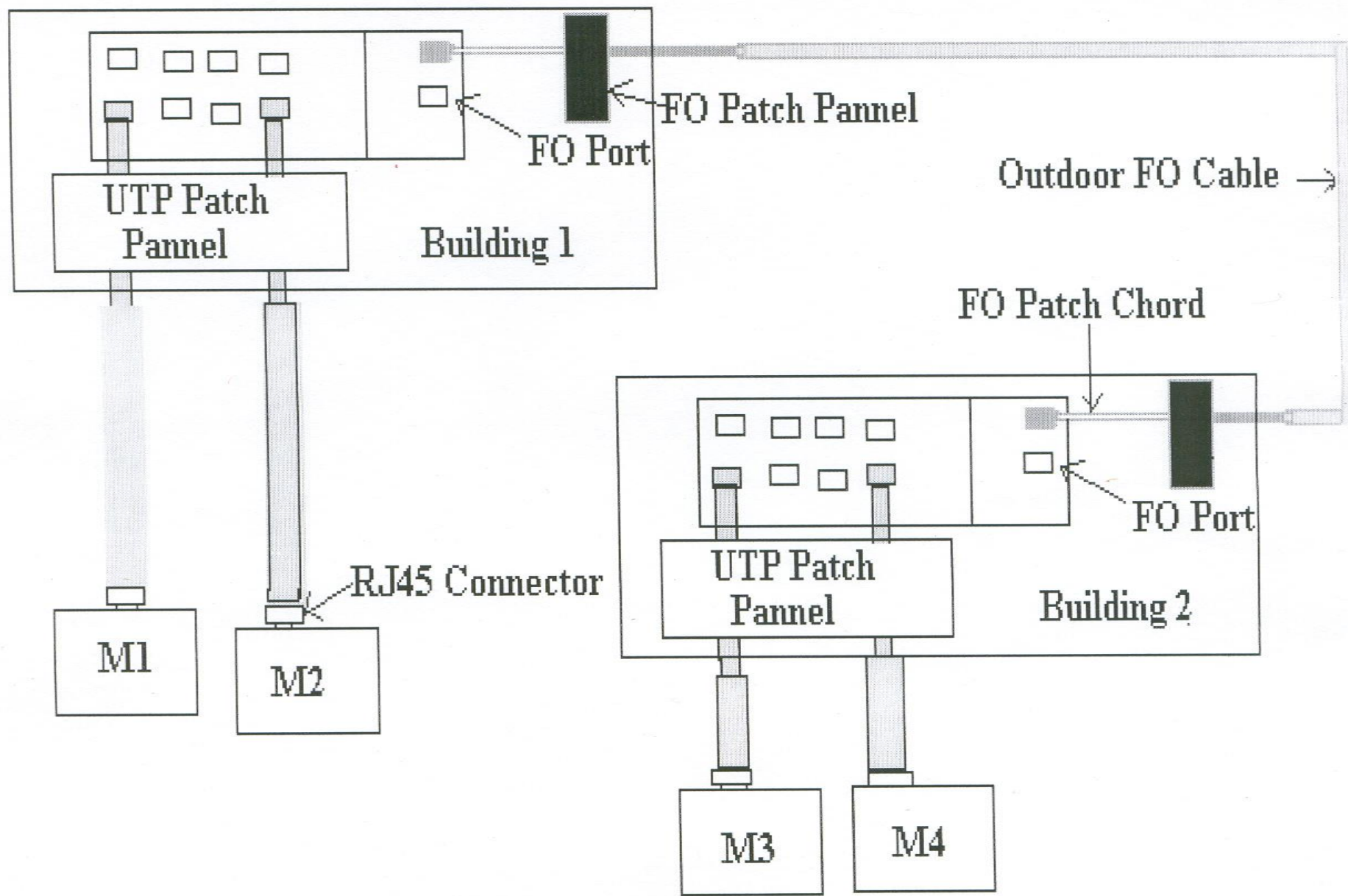

Composite FO/UTP Network for different Buildings

BUS TOPOLOGY OF LAN

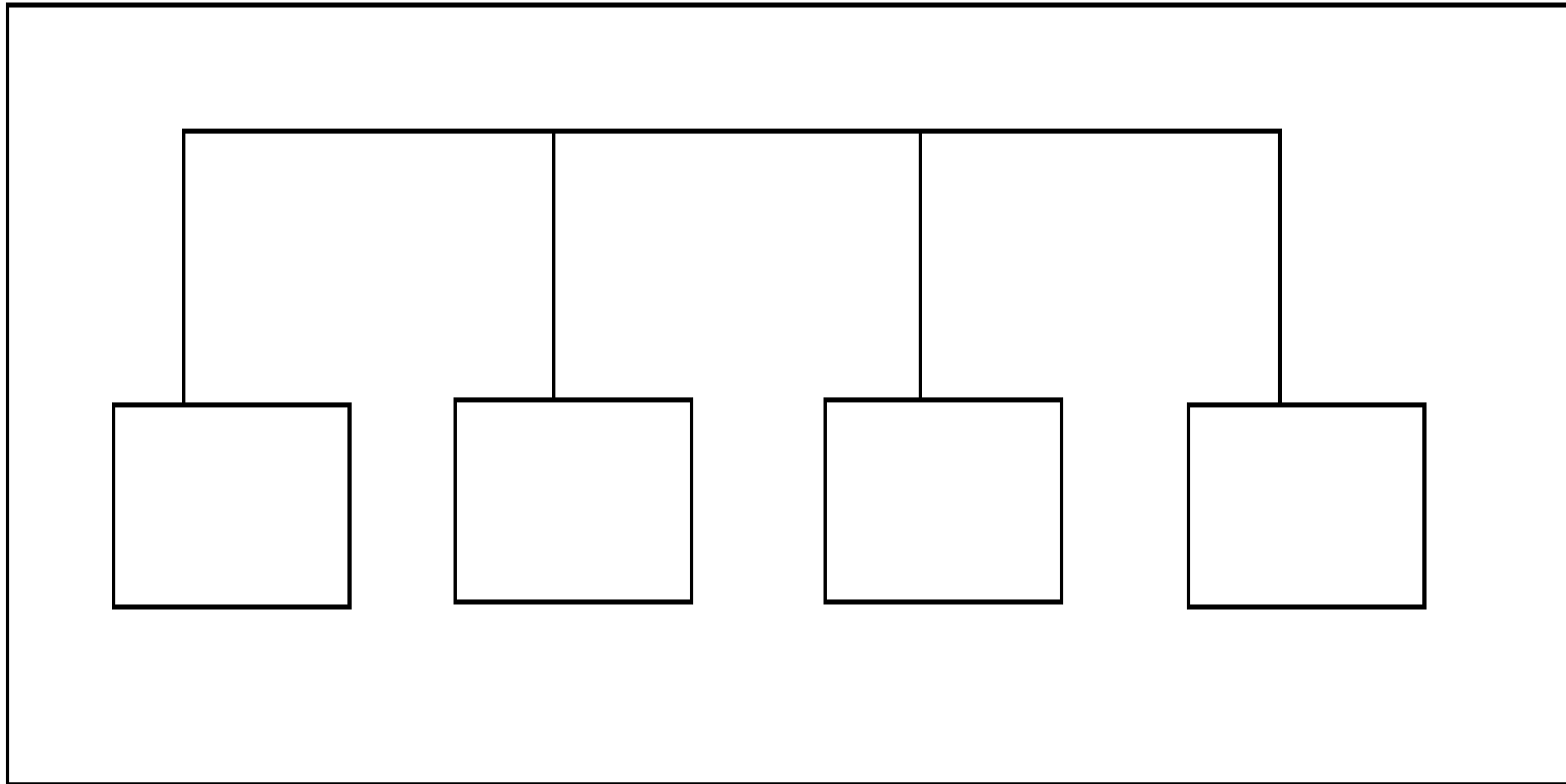

DISTRIBUTED APPLICATIONS IN E-COMMERCE

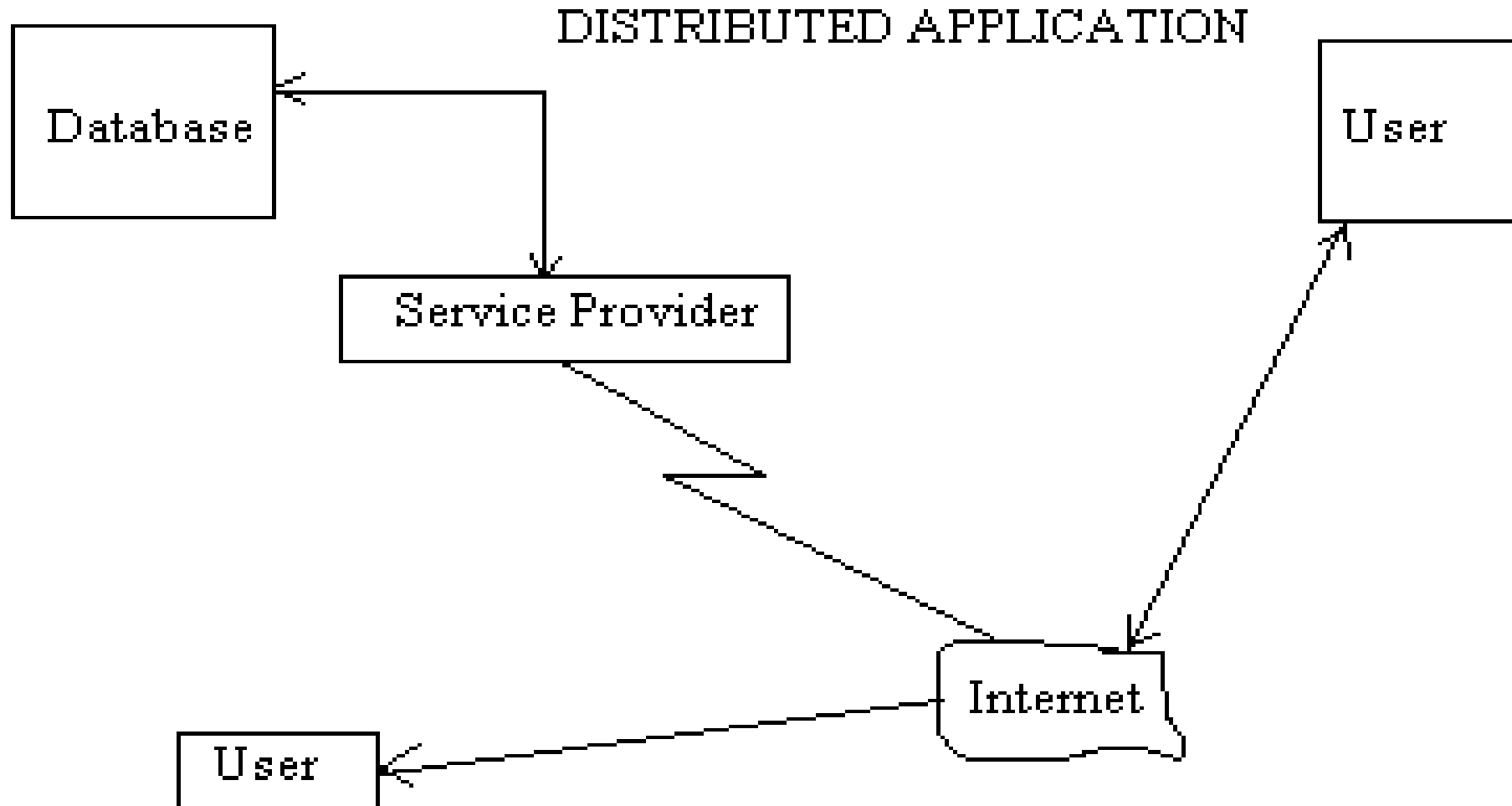

OBJECT MODELS OF E-COMMERCE

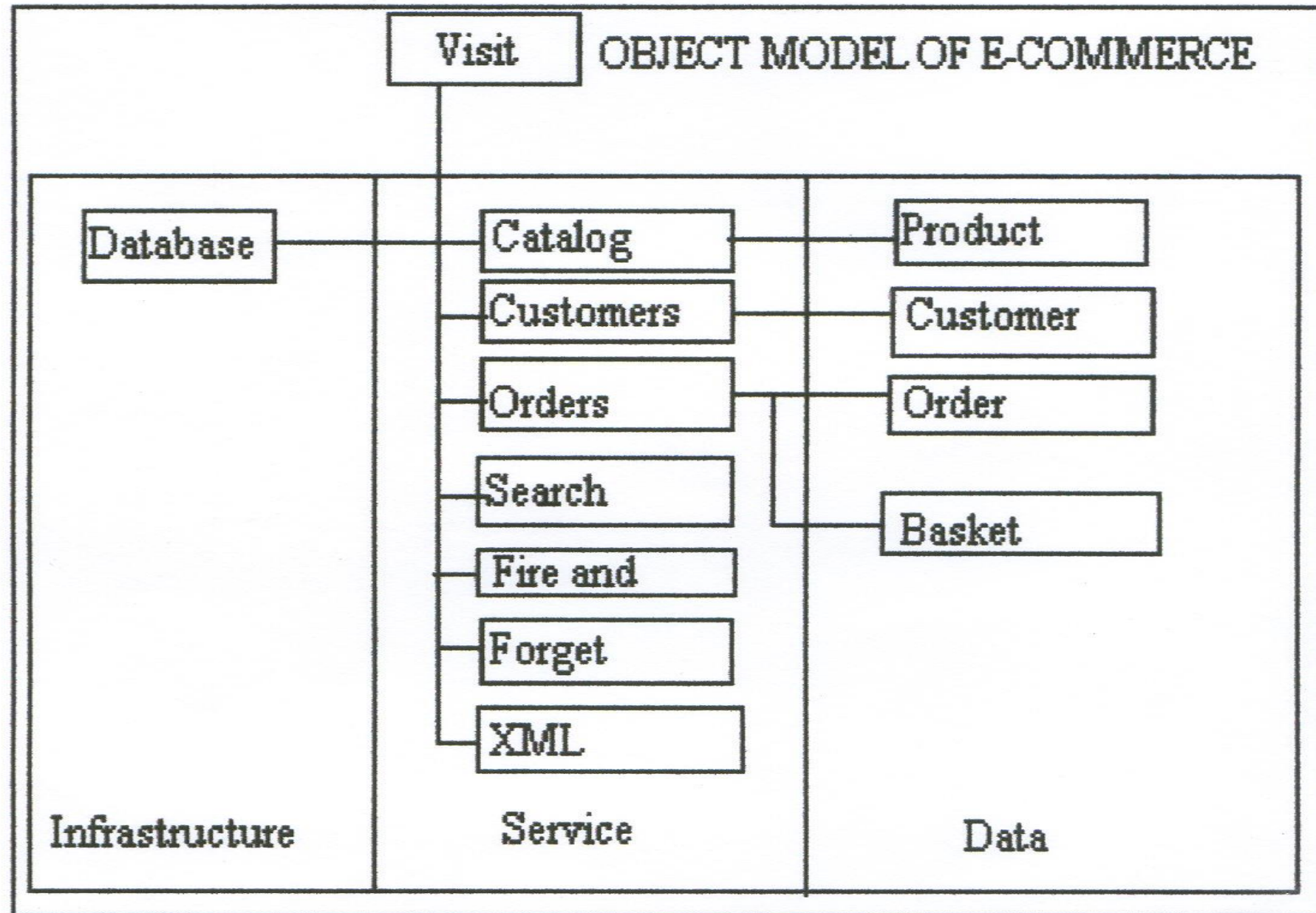

3-TIER SYSTEM OF E-COMMERCE

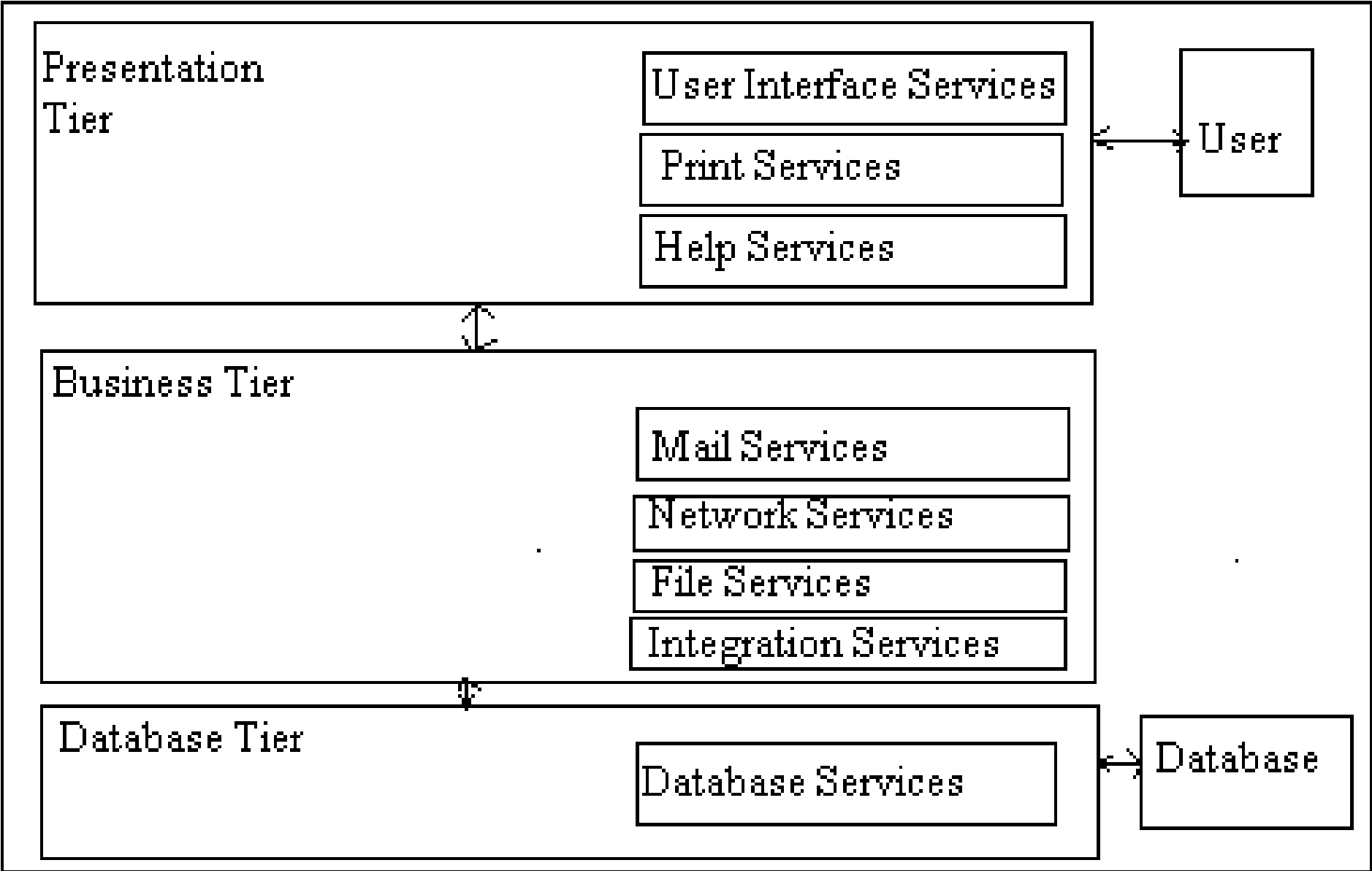

WEB SERVER CONFIGURATIONS

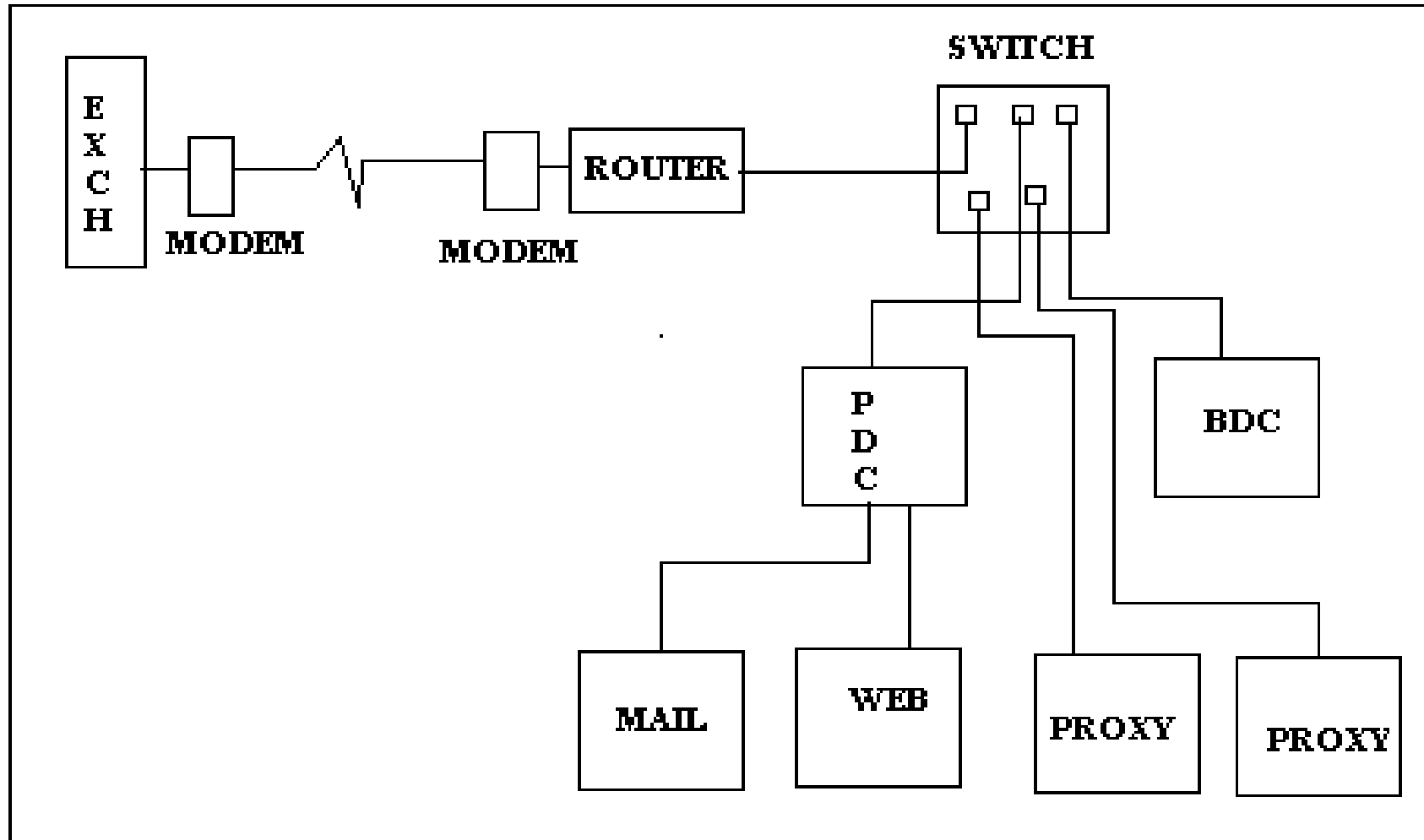

TELEPHONE CONNECTIVITY THROUGH EXISTING CAMPUSWIDE LAN SETUP

Various Departments (buildings) are connected through 6-core multimode FO Cable, where two cores are being used for data network. Each department has a CISCO (Managed) Switch. FO cables are connected to these switches either through direct FO port or through FO/UTP Converter. Connectivity within a department is made through UTP Cabling. There is at least one connection in each department.

TELEPHONE CONNECTIVITY THROUGH EXISTING CAMPUSWIDE LAN SETUP

It is proposed to have a central EXCHANGE compatible with this FO network and this will be located at main switching room of computer center under the existing central UPS connectivity. Initially five telephone connectivity (from external telephone exchange) to be integrated with this Exchange from existing P&T junction box already installed inside the switch room of computer center. The external connectivity will be distributed throughout the campus using existing FO network from the exchange. So exchange must have capability of integrating external telephone connectivity through this FO backbone .

Main EPABX should have

- 1. Fully digital with distributed Processor / Supply Architecture**
- 2. Non-blocking Architecture**
- 3. Module-wise expandability up to 248 ports or in the same box and beyond with additional box**
- 4. Provision for Ch E1, ISDN BRI, ISDN PRI, E&M ports etc.**
- 5. Welcome voice message with different level voice guidance.**
- 6. Direct dialing of Extn. / Automated Operator assistance.**
- 7. Detail Accounting / Budget of calls.**
- 8. Automated call restriction / STD locking for internal /external lines**
- 9. Integratable with FO network, CISCO Switches and DLINK HUBs**

Major features of these VoIP Boxes includes

- 1. 1 no. 10/100 Base Tx UTP port**
- 2. 8/24 nos. voice ports**
- 3. Voice compression**
- 4. H.323 compliant**
- 5. SNMP supported**
- 6. Web-based management**



Major features of these VoIP Boxes includes

1. 1 no. 10/100 Base Tx UTP port
2. 8/24 nos. voice ports
3. Voice compression
4. H.323 compliant
5. SNMP supported
6. Web-based management

Main EPABX proposed should have

1. Fully digital with distributed Processor / Supply Architecture
2. Non-blocking Architecture
3. Module-wise expandability up to 248 ports or in the same box and beyond with additional box
4. Provision for Ch E1, ISDN BRI, ISDN PRI, E&M ports etc.
5. Welcome voice message with different level voice guidance.
6. Direct dialing of Extn. / Automated Operator assistance.
7. Detail Accounting / Budget of calls.
8. Automated call restriction / STD locking for internal /external lines
9. Integratable with FO network, CISCO Switches and DLINK HUBs

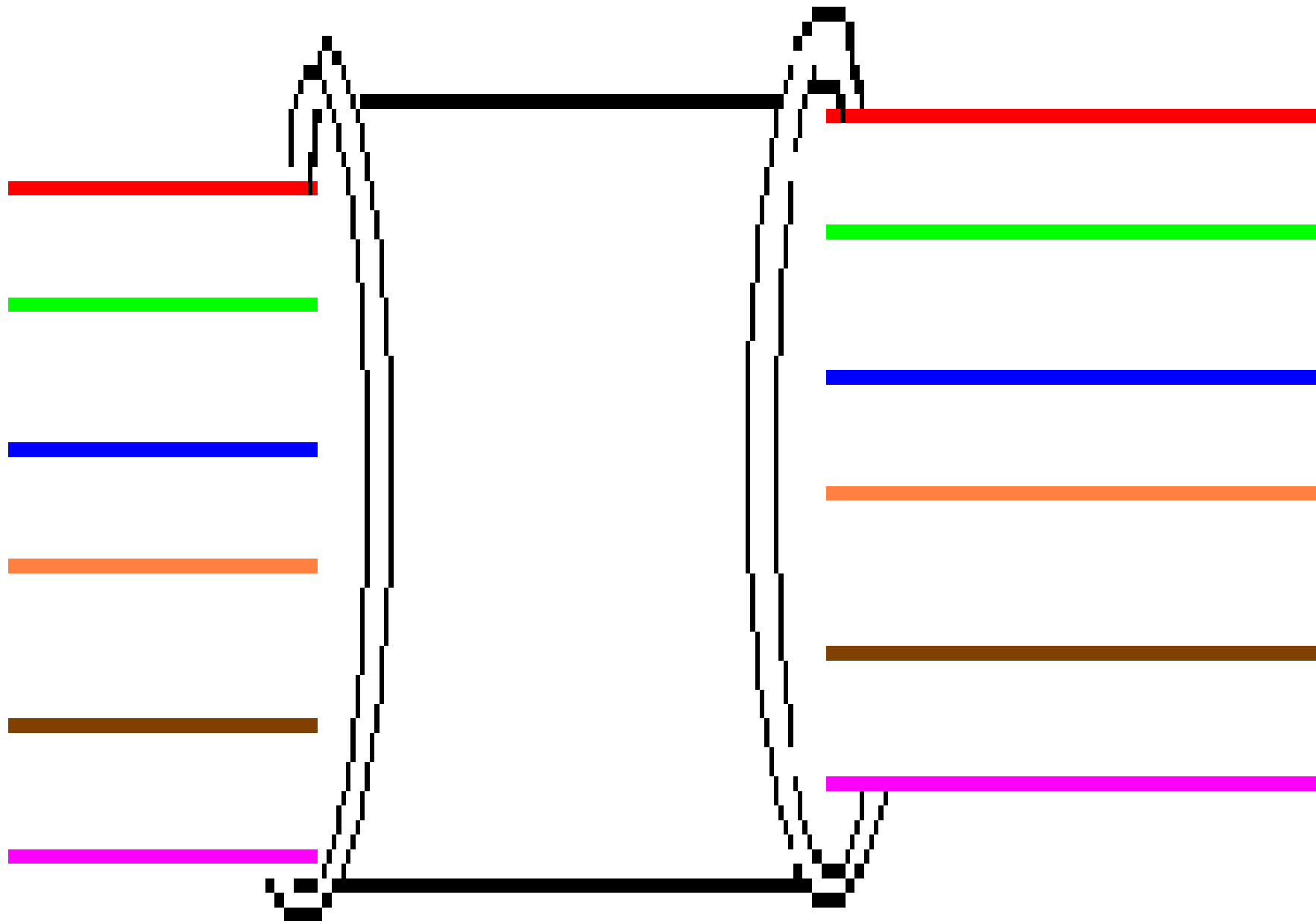

- Optimal design using existing infrastructure
- No outdoors wiring among VoIP boxes and proposed exchange – it will use only existing LA backbone
- Routing of incoming calls to individual departments/person should be done without manual intervention.

Detailed Layout of the Telephone Connectivity

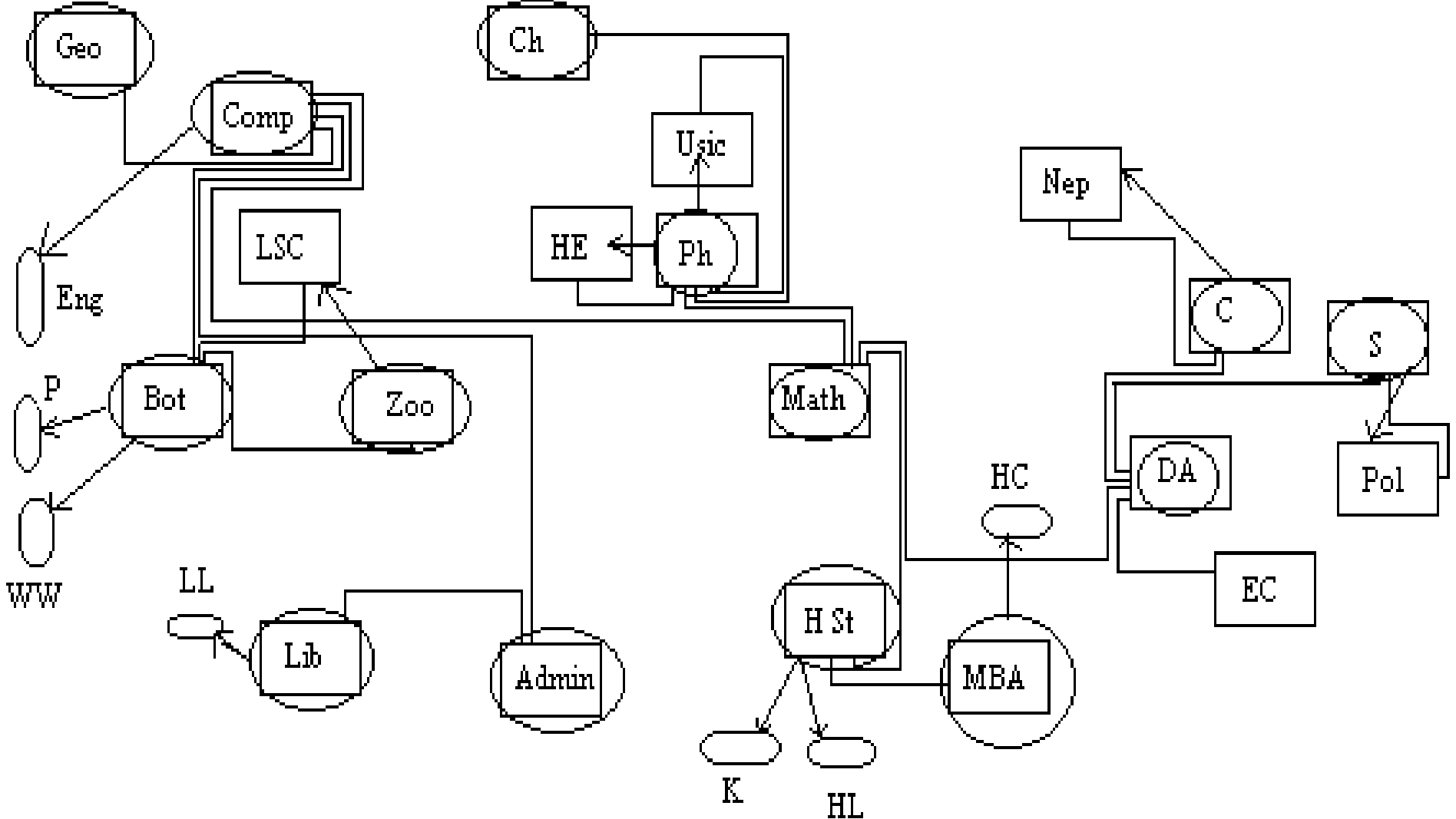

CONNECTIVITY OF DISTRIBUTOR BUILDINGS

THE BUILDINGS UNDER THIS CATEGORY: 1) MATHEMATICS
2) DEAN ARTS

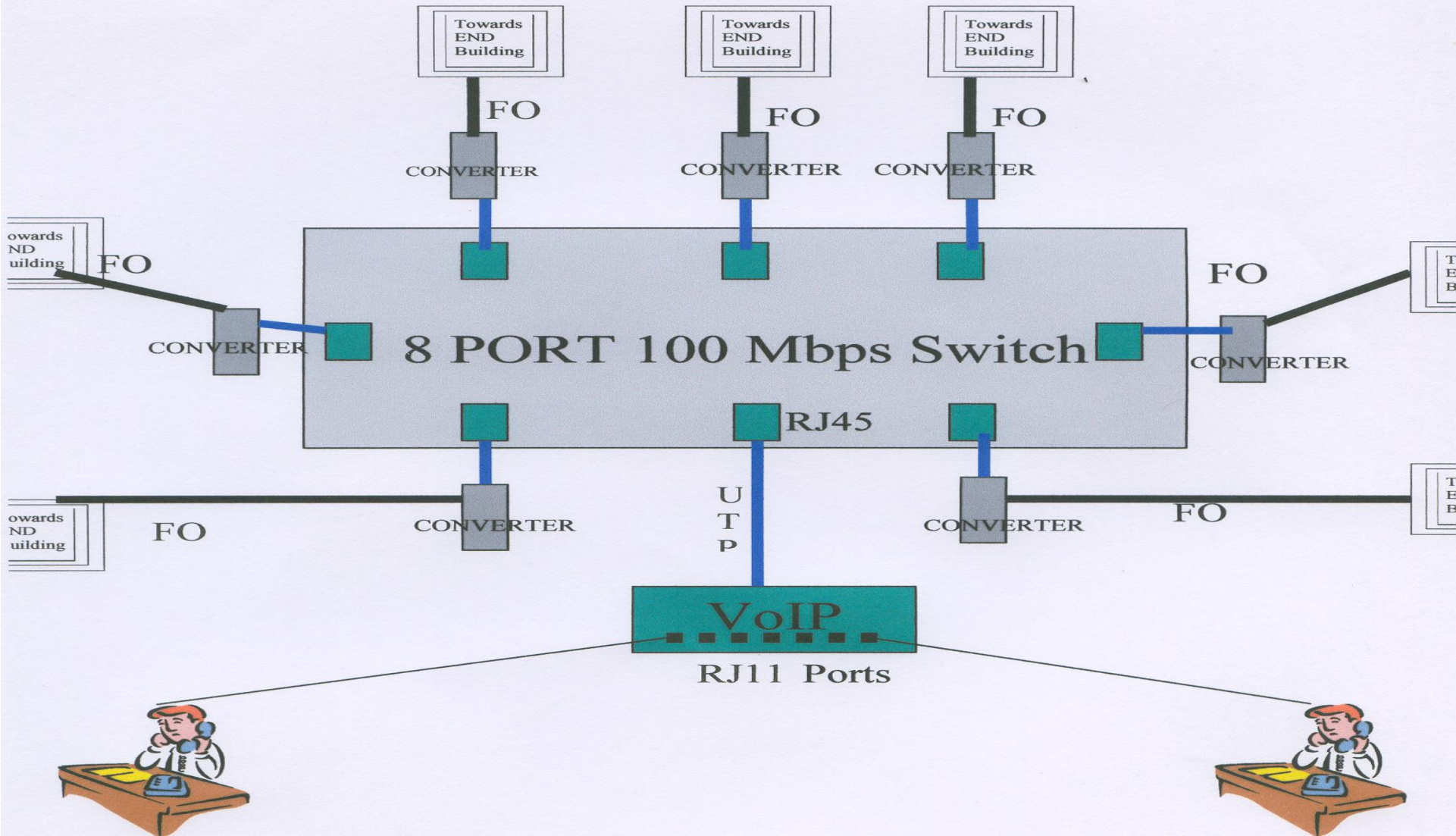

END BUILDINGS

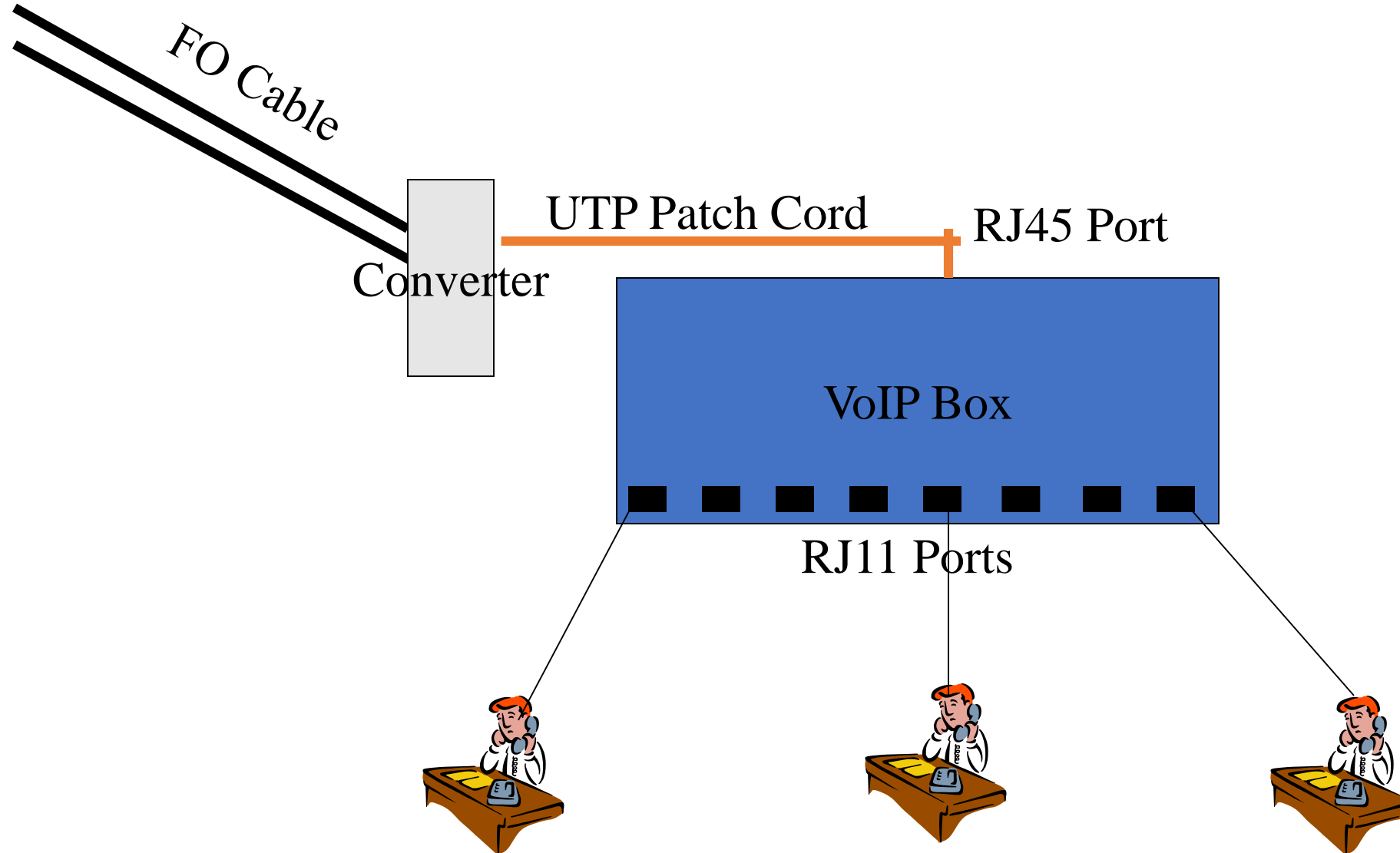

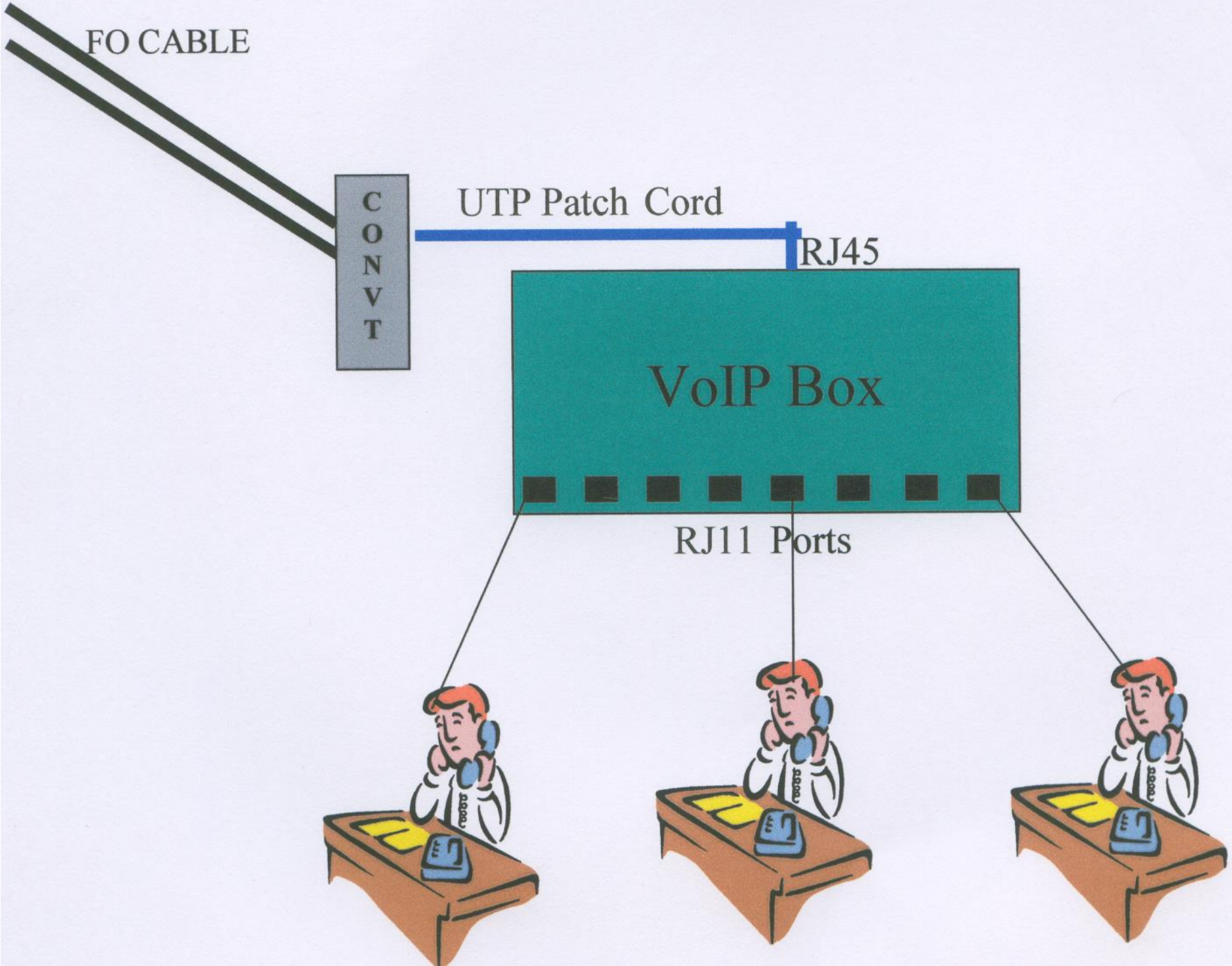

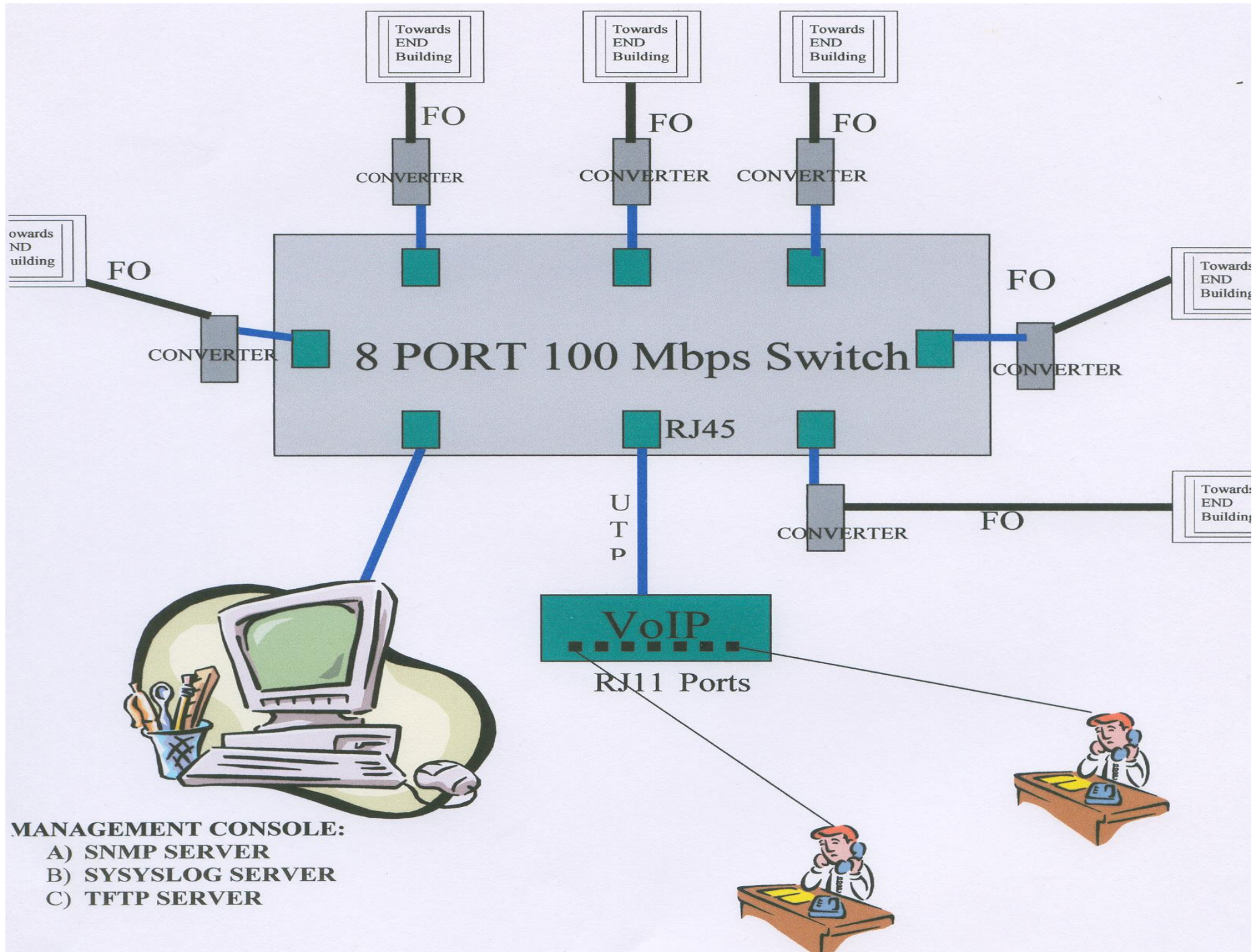

- MANAGEMENT CONSOLE:**
- A) SNMP SERVER
 - B) SYSLOG SERVER
 - C) TFTP SERVER

Connectivity Plan between University and its Constituent Colleges

- A central router come RAS may be proposed at Main Switching room with two channelised E1 port.
- At a, time maximum 60 (2 x 30) colleges can get connected.
- The remote colleges will use PSTN dial-up line.
- One PC at each remote location is proposed with in-built modem, multimedia and compatibility to Video Telephony.
- Channelised E1 is preferred connectivity between NBU and nearest exchange

Connectivity between Local Exchange and Main Switching Centre may be replaced by Fiber Optical cables for effective communication.

ESTABLISHED UBKV LAN WITH LIBRARY NETWORK AND LEASED LINE

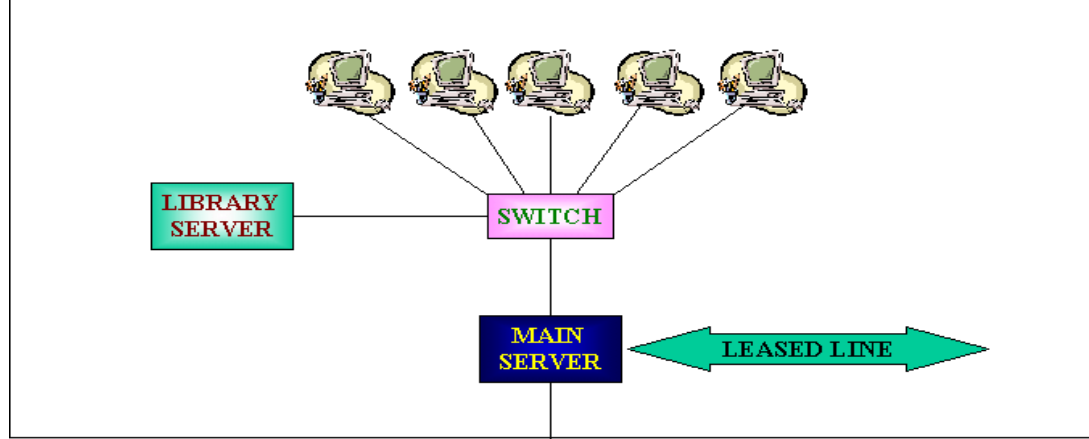

PROPOSED UBKV WAN

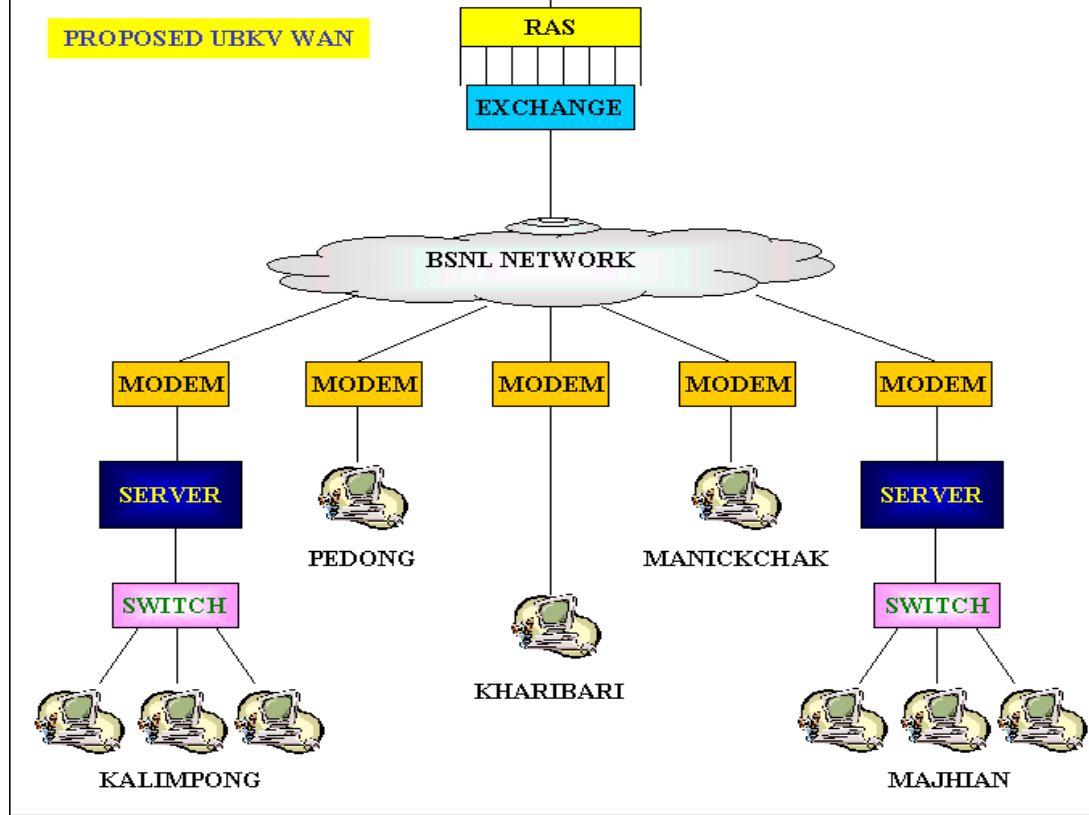

PROPOSED STRUCTURE OF THE UBKV-WAN

Connectivity Plan between University and its Constituent Colleges

- **A central router come RAS is proposed at Main Switching room with two channelized E1 port.**
 - ∅ **At a, time maximum 60 (2 x 30) colleges can get connected.**
 - ∅ **The remote colleges will use PSTN dial-up line.**
 - ∅ **One PC at each remote location is proposed with in-built modem, multimedia and compatibility to Video Telephony.**
 - ∅ **Channelised E1 is preferred connectivity between NBU and nearest exchange**
- Connectivity between Local Exchange and Main Switching Centre may be replaced by Fiber Optical cables for effective communication.**

Salient feature of the proposed backbone :

- ✓ **End to end connectivity**
- ü **All colleges may be covered**
- ü **Video Telephony Enabled**
- ü **Browsing of Internet through NBU LAN**
- ü **Channelised E1 for elegant and better managability, and cost-effectiveness**
- ü **Enough provision for future upgrade**
- ü **Investment Protection**
- ü **Same Router can be used for ISDN lines without any additional investment in router**
- ü **File transfer from remote colleges to University**

Access to University LAN, including servers, from remote colleges

SCHEMATIC DIAGRAM OF CONNECTIVITY THROUGH E1 CHANNEL

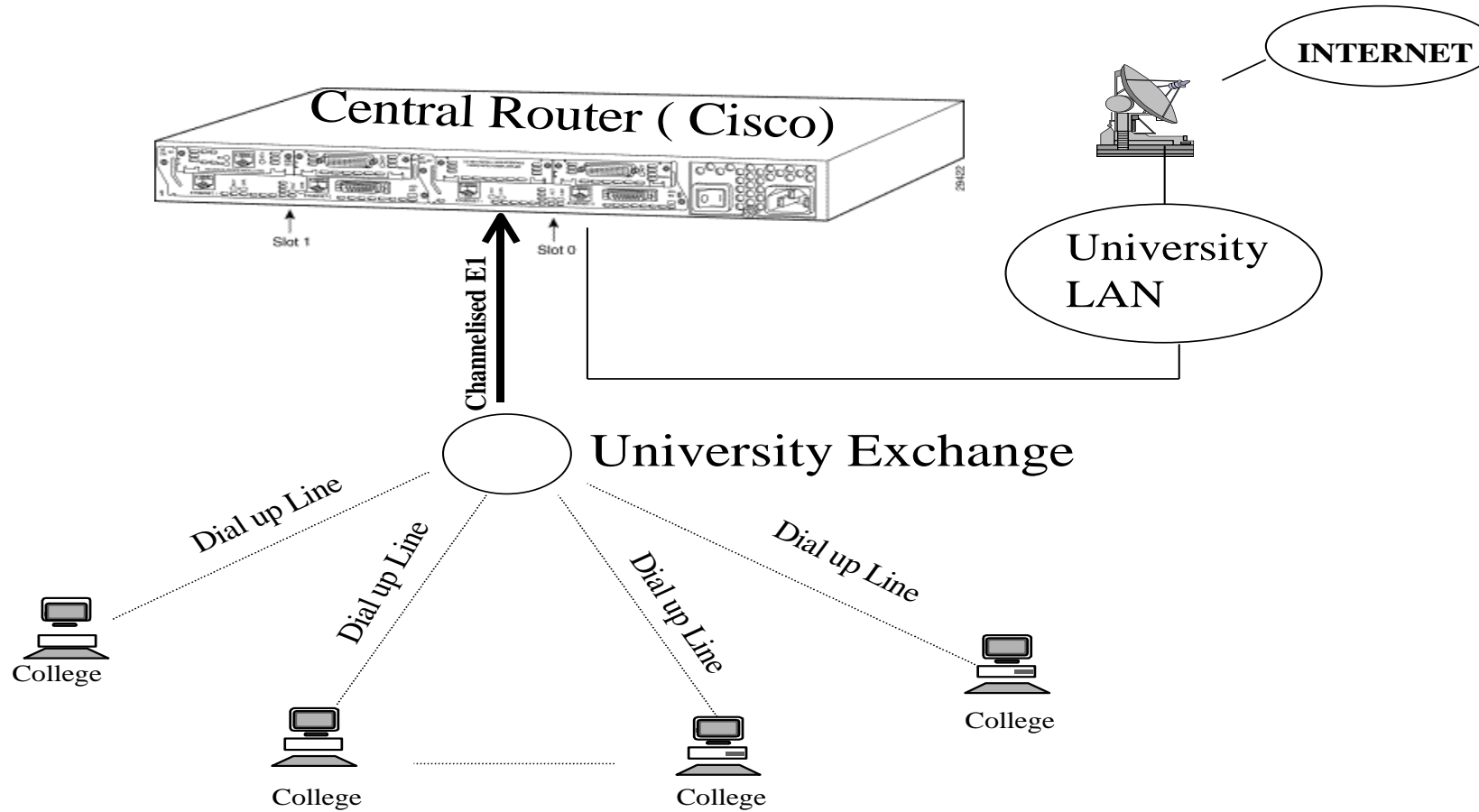

Connectivity between University and Constituent colleges under it

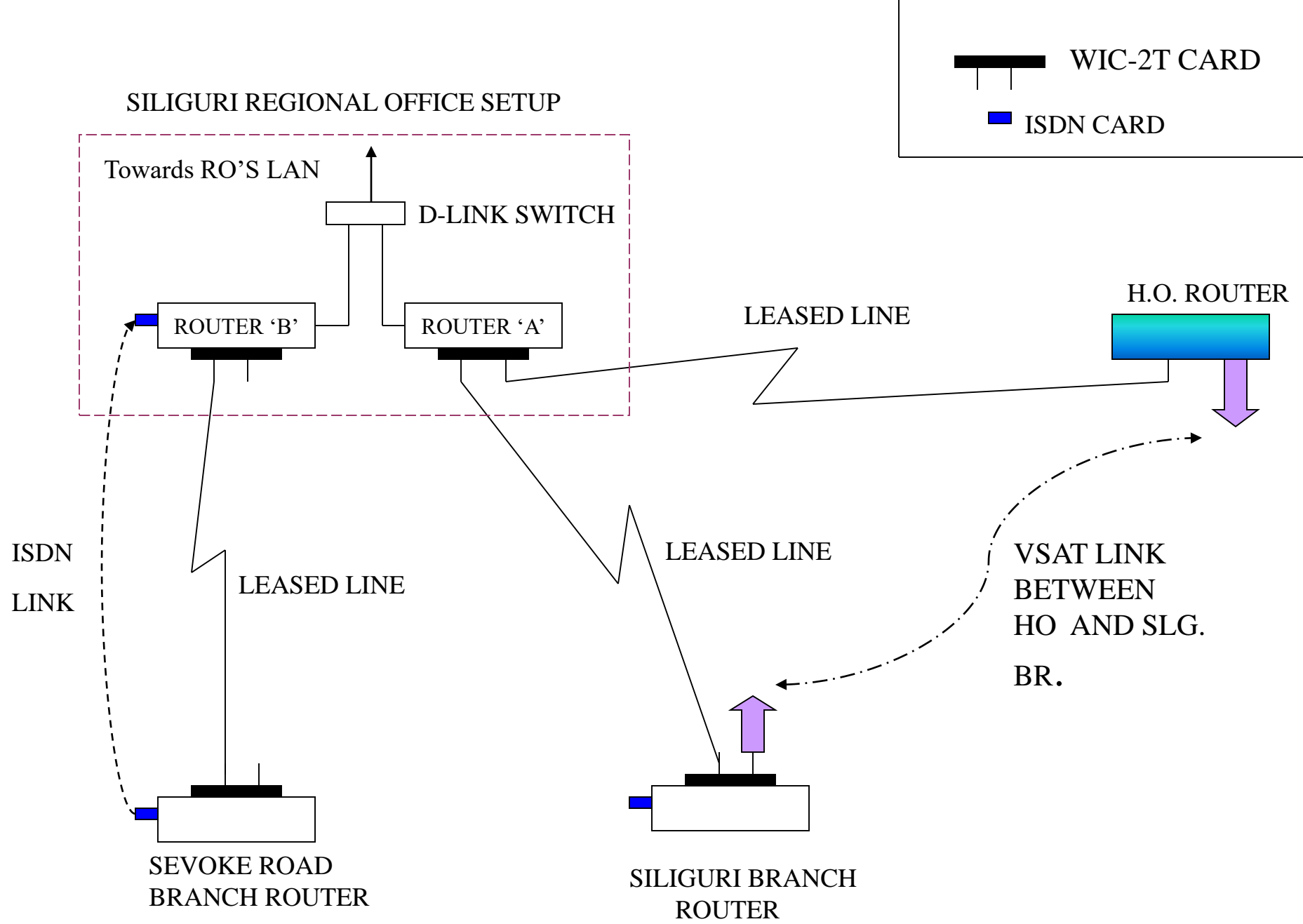

ESTABLISHED UBKV LAN WITH LIBRARY NETWORK AND LEASED LINE

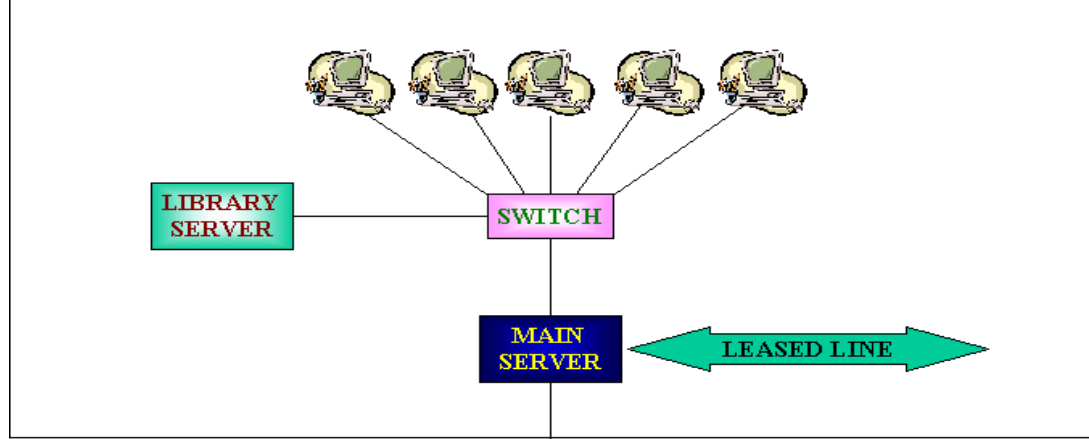

PROPOSED UBKV WAN

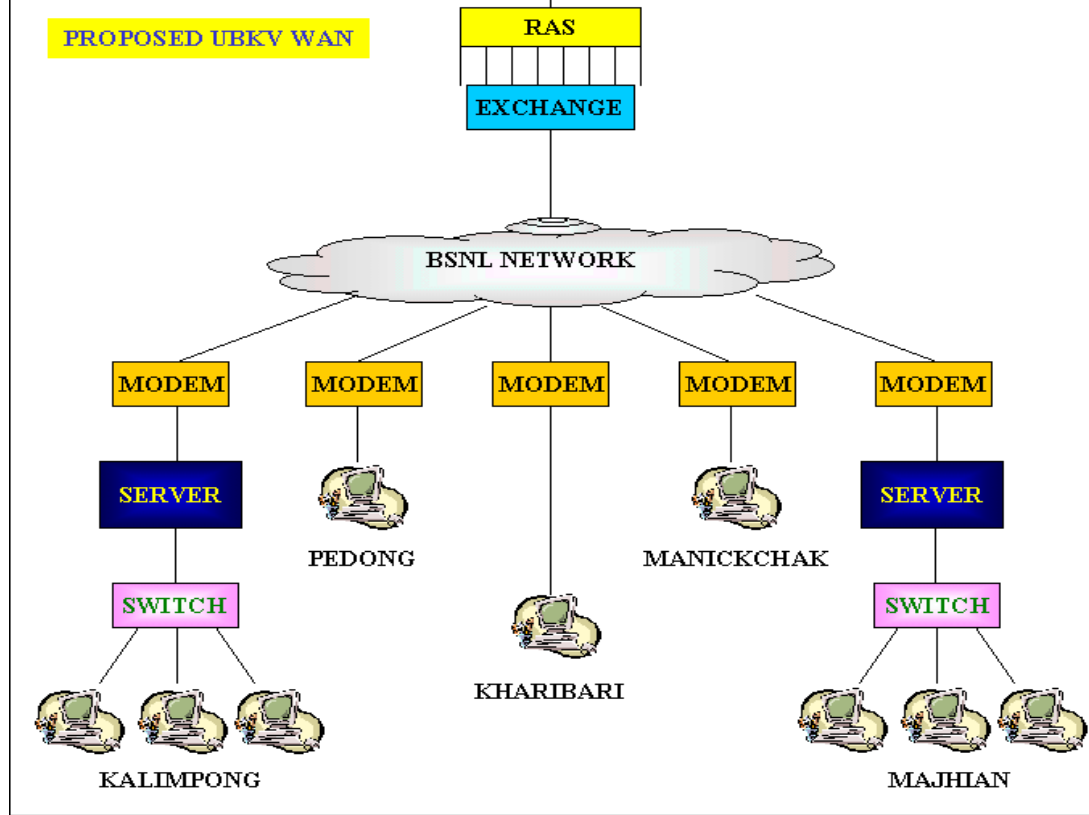

PROPOSED STRUCTURE OF THE UBKV-WAN

OVERALL REPRESENTATION OF THE LAN & INTERNET SYSTEM

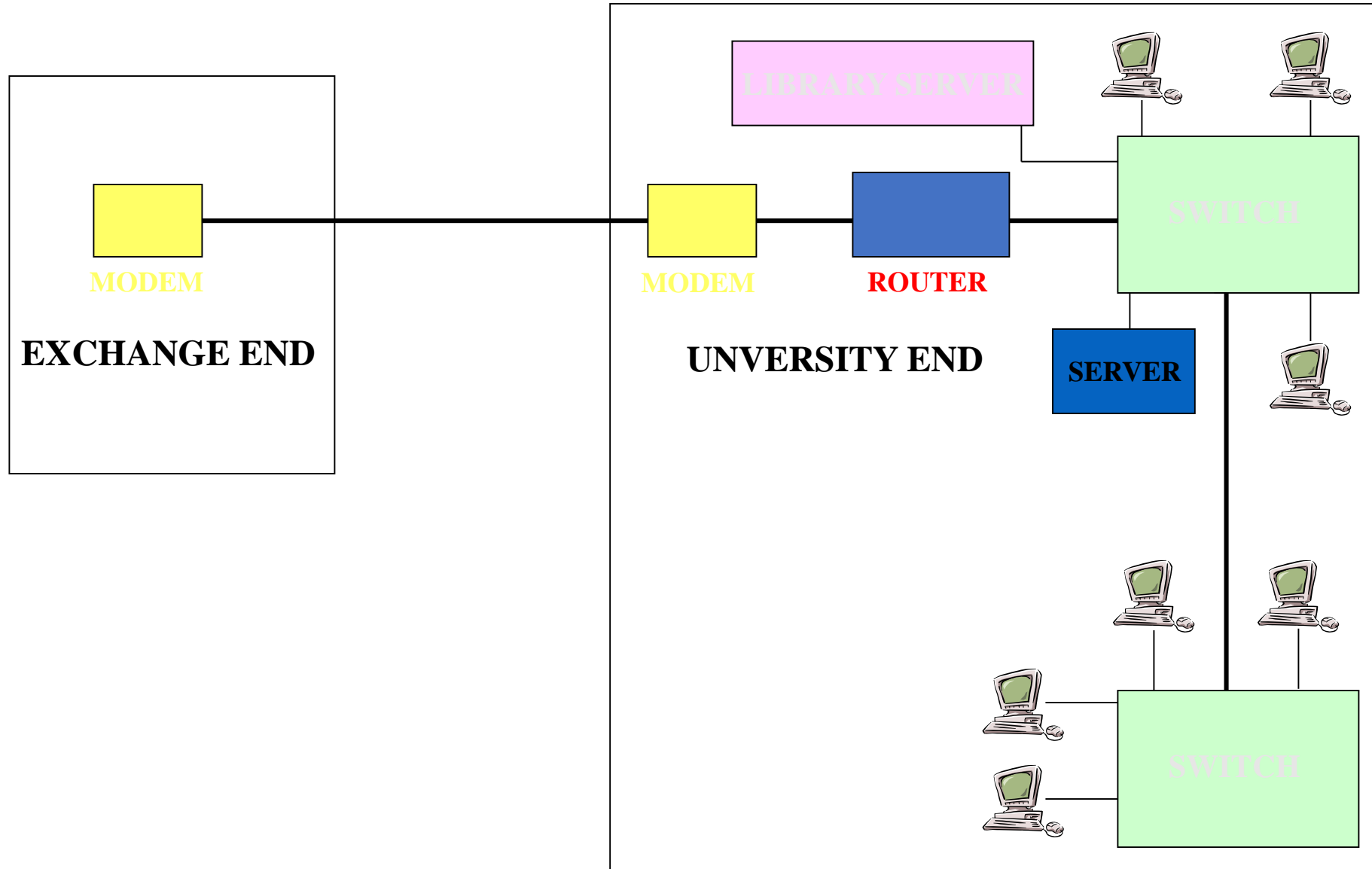

Inter City connectivity

